

BAS-315E

**Programmable Electronic Pattern Sewer
with Cylinder Bed
<With Automatic Single Label Feeder>**



Specifications

Machine head	Lock stitch pattern tacking sewing machine (with large shuttle hook)	
Sewing speed	2,500 rpm (When stitch length is 3 mm or less)	
Stitch length	0.05 mm - 12.7 mm	
Sewing area X - Y	Roll label type Rectangular sewing : X 20-80 mm Y 16 - 40 mm Two vertical sewing : X 20-80 mm Y 16 - 38 mm Cut label type Rectangular sewing : X 20-100 mm Y 16 - 60 mm Two vertical sewing : X 20-100 mm Y 16 - 58 mm	
	2HD	2DD
Interchangeable with A series	X	○
No. of new stitches / edit	Max. 20,000	Max. 4,000
No. of stitches / program	Max. 50,000	Max. 4,000
No. of stitches / floppy disk	Max. 360,000	Max. 40,000
No. of data	Max. 100 pcs.	Max. 10 pcs.
Feed mechanism	Stepping feed, pulse motor drive	
Max. height of work clamp	20 mm	
Needle	DP × 17	
Minimum resolution	0.05 mm	
Test function	Operation test function provided for use with low speed drive	
Safety device	Automatic stop function for activation in the event of mioperation realized with intermediate stop function and safety circuits	
Motor	Three-phase 400 W induction motor	
Data storage method	3.5 floppy disk 2HD / 1.44 MB, 2DD	
Air pressure	0.5 Mpa 1.8 l / min	
Power supply	Three-phase 220 V, 380 V, 400 V, 600 VA	
Machine dimensions	Roll label type Standing : (W) 1,200 x (D) 710 x (H) 1,550 mm Sitting : (W) 1,200 x (D) 710 x (H) 1,270 mm Cut label type Standing : (W) 1,200 x (D) 880 x (H) 1,530 mm Sitting : (W) 1,200 x (D) 880 x (H) 1,250 mm	
Weight	140 kg	

BAS-315E- 2-

Programmer		Specifications		Power supply	
1	No	1	Cut label type	01	Three-phase 200V
2	Yes	2	Roll label type	10	Three-phase 220V
				11	Three-phase 380V
				20	Three-phase 400V

GAUGE PARTS LIST

Needle hole plate

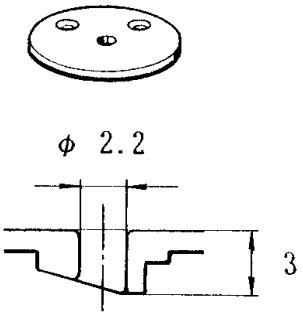
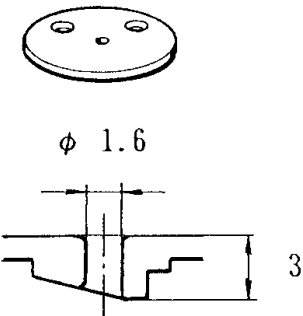
Needle hole plate, F S10213-001	Needle hole plate, A S10211-001
 <p>ϕ 2.2</p> <p>3</p>	 <p>ϕ 1.6</p> <p>3</p>

Thread trimmer mechanism

Movable knife assy, L S40934-001

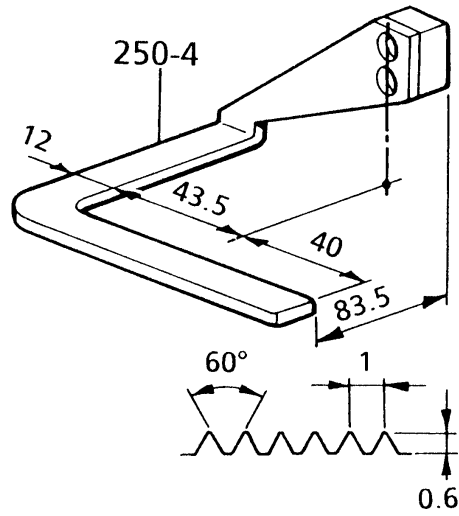
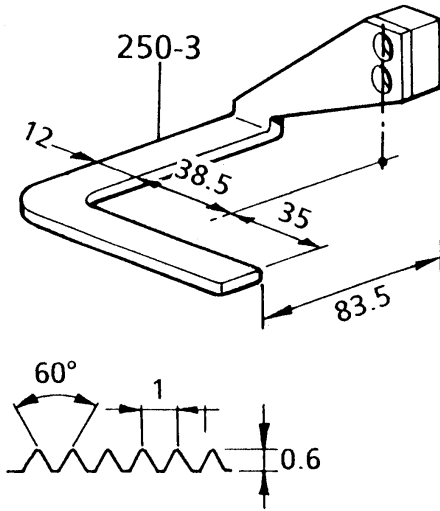
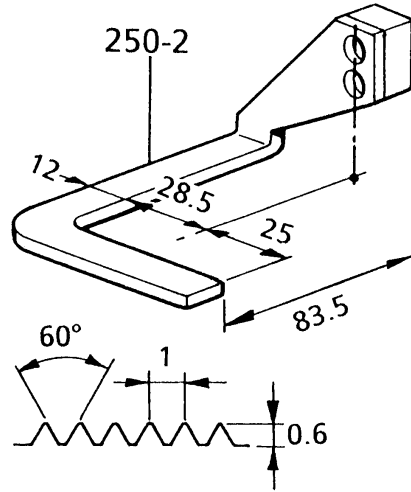
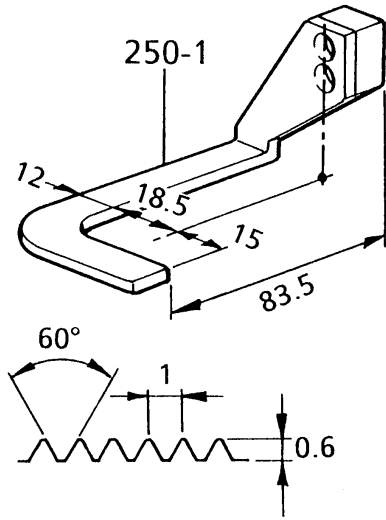

* This is used to prevent thread cast-off.

External work clamps

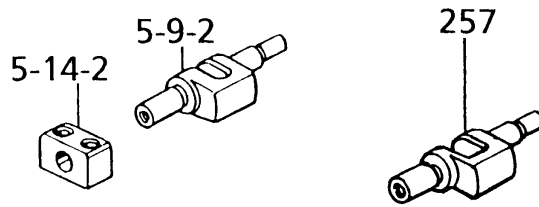

Ref. No.	Partname	Partcode	Q'ty
< For X - axis dimension 20 - 30 mm >			
250-1	External work clamp, 20 - 30mm	S31282-001	1
< For X - axis dimension 30 - 50 mm >			
250-2	External work clamp, 30 - 50mm	S31283-001	1
< For X - axis dimension 50 - 70 mm >			
250-3	External work clamp, 50 - 70mm	S31284-001	1
< For X - axis dimension 70 - 80 mm >			
250-4	External work clamp, 70 - 80mm	S31285-001	1

Feed mechanism (Option parts)



Ref. No.	Part name	Part code	Q'ty
< For Y-axis dimension 20–40mm >			
5	Presser crank assy, LA	S12633-209	1
5-9-2	Work clamp crank, LA	S05665-001	1
5-14-2	Work clamp plate holder, L	154237-001	1
< For Y-axis dimension 16–20mm >			
5	Presser crank assy, S	S18054-209	1
5-9-2	Work clamp crank, S	154297-001	1
5-14-2	Work clamp plate holder, S	154291-001	1
< For Y-axis dimension 12–16mm >			
257	Work clamp crank, SS	S04516-001	1

Feed mechanism (Option parts)

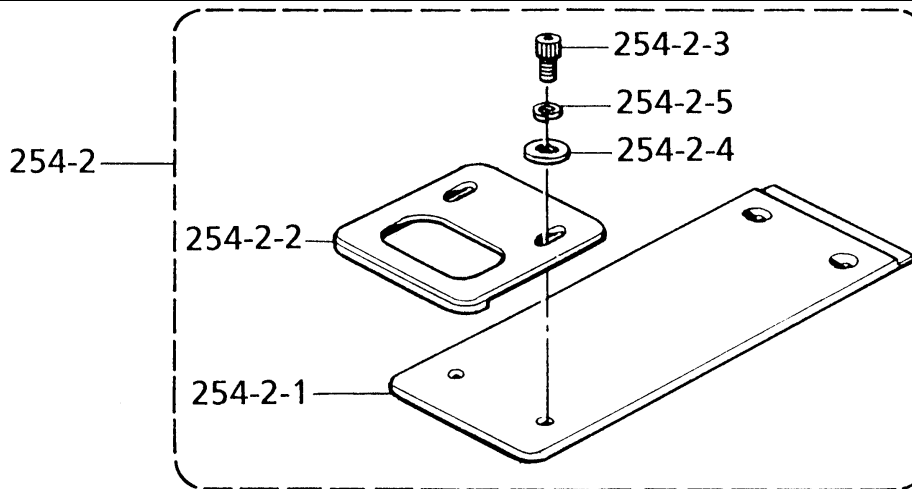

Ref. No.	Part name	Part code	Q'ty
254-2	Feed plate assy, IJ	S31281-001	1
254-2-1	Feed plate, IJ	S31278-000	1
254-2-2	Cloth caul, IJ	S31279-000	1
254-2-3	Bolt, socket M3×4	018300-436	2
254-2-4	Washer, plain M3	025030-234	2
254-2-5	Washer, spring 2-3	028030-246	2

Feed mechanism (Option parts)

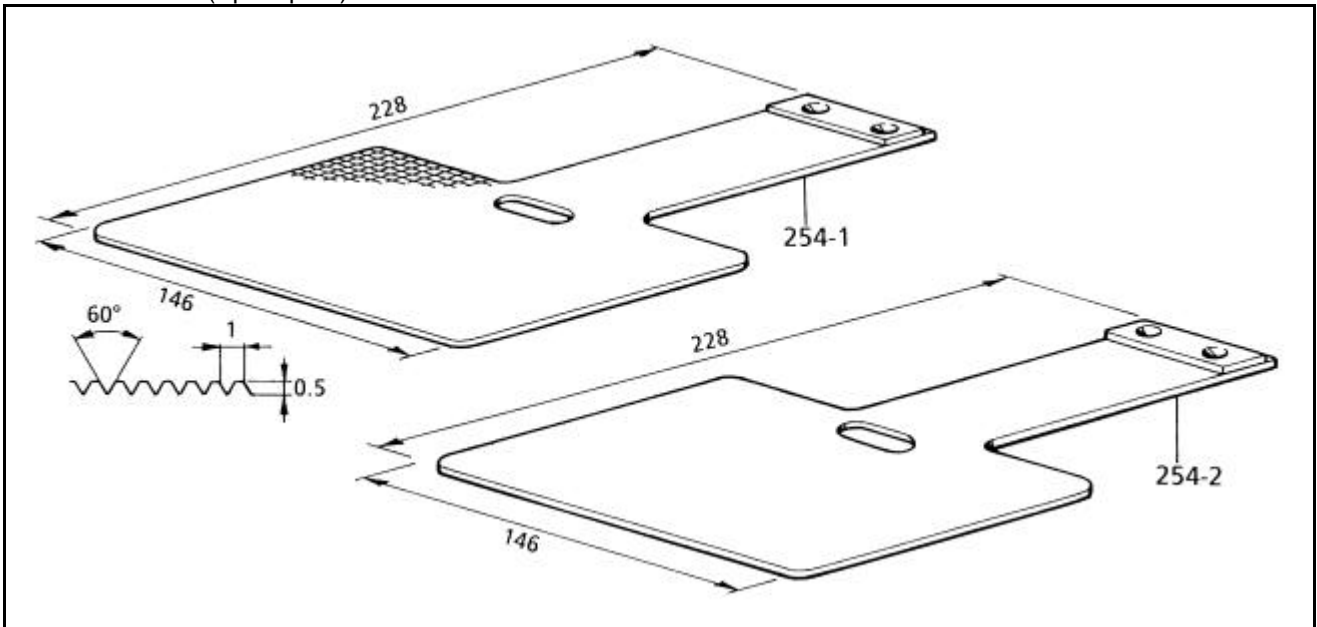

Ref. No.	Part name	Part code	Q'ty
254-1	Feed plate blank, 312- 1 t = 1.2	S12645-001	1
254-2	Feed plate blank, 315- 1 t = 1.2	S30638-001	1

Feed mechanism (Option parts)

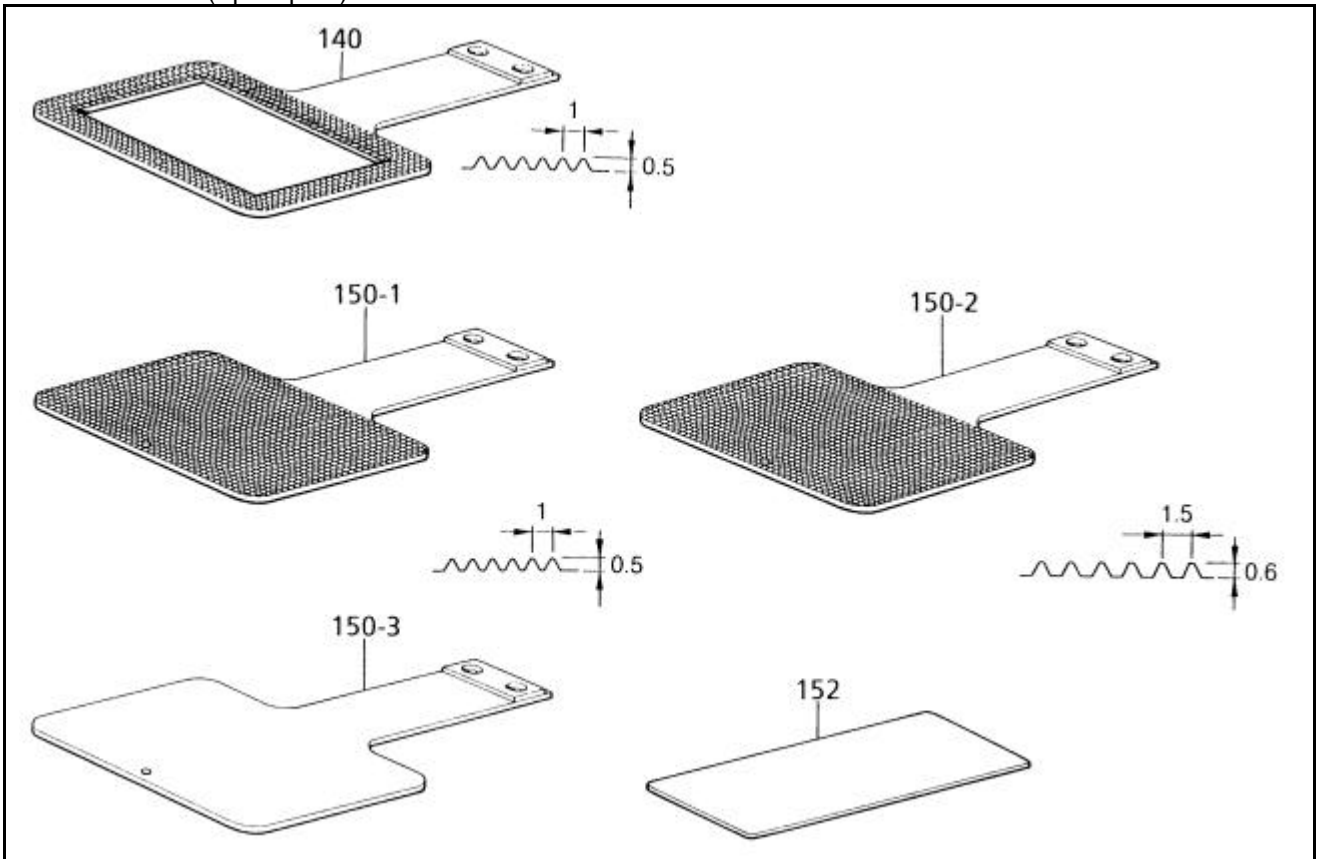

Ref. No.	Part name	Part code	Q'ty
< Feed plate >			
140	Feed plate, 311A	S42777-001	1
< For feed plate attachment >			
150-1	Feed plate blank, A311 t = 1.2	S43697-001	1
150-2	Feed plate blank, B311 t = 1.2	S43698-001	1
150-3	Feed plate blank, C311 t = 1.2	S43699-001	1
152	Feed plate inner plate	S43823-001	1

Work clamp

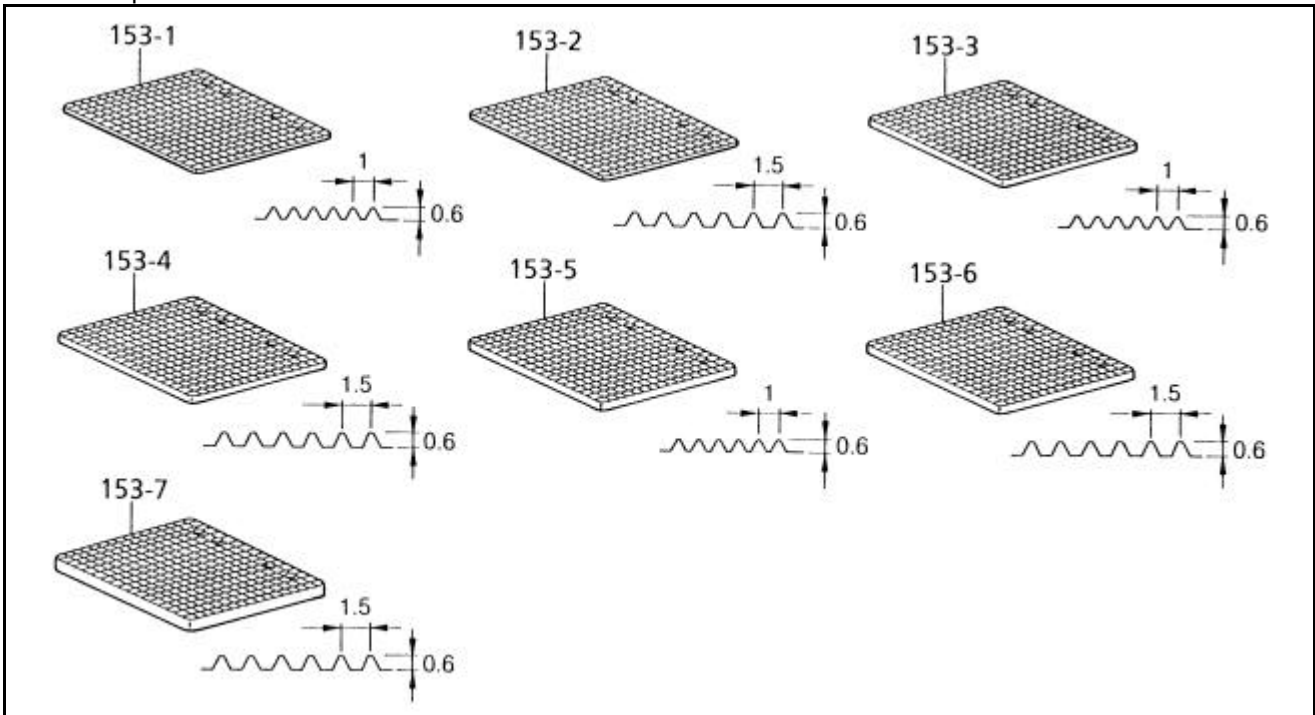

Ref. No.	Part name	Part code	Qty
<Blank for work clamp>			
153-1	Work clamp blank, A - 3.2 t = 3.2	S43824-001	1
153-2	Work clamp blank, B - 3.2 t = 3.2	S43825-001	1
153-3	Work clamp blank, A - 4.0 t = 4.0	S43826-001	1
153-4	Work clamp blank, B - 4.0 t = 4.0	S43827-001	1
153-5	Work clamp blank, A - 5.0 t = 5.0	S43828-001	1
153-6	Work clamp blank, B - 5.0 t = 5.0	S43829-001	1
153-7	Work clamp blank, 6.0 t = 6.0	S43830-001	1

Work clamp

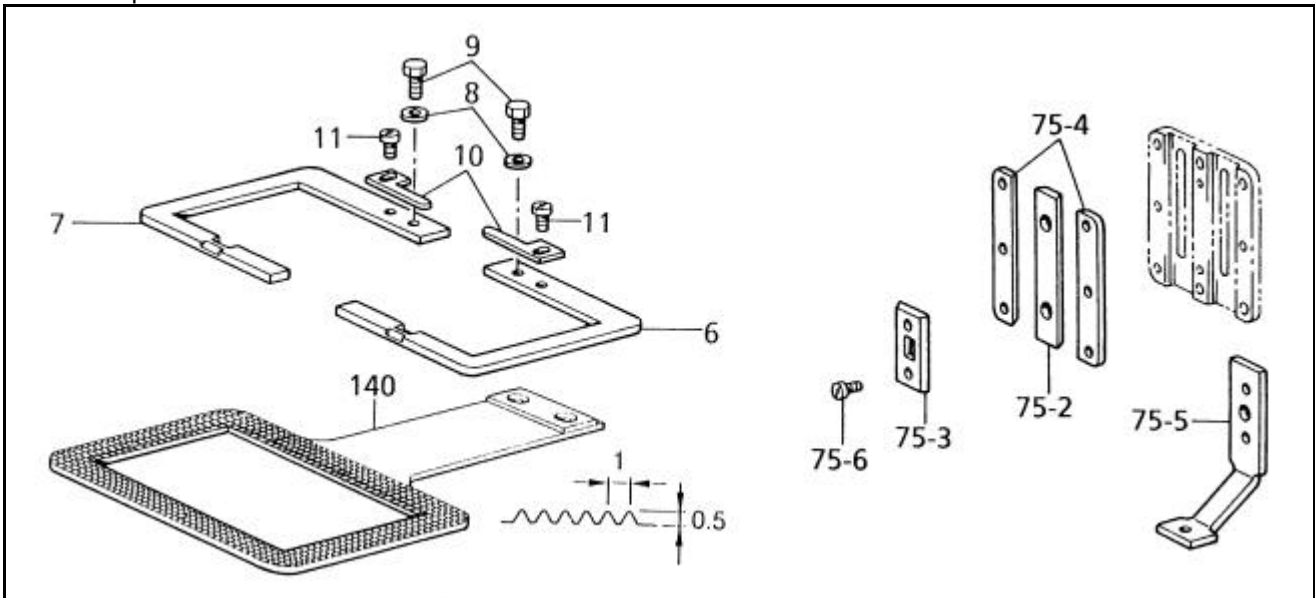

Ref. No.	Partname	Partcode	Q'ty
6	Work clamp, R311	S42772-001	1
7	Work clamp, L311	S42773-001	1
8	Washer, plain M4.37	025680-232	2
9	Bolt, SM4.37×7	153403-002	2
10	Positioning plate	S10065-001	2
11	Screw, pan SM4.37 - 40×5	062680-512	2
75-2	Work clamp guide bracket	S42798-001	1
75-3	Work clamp adjusting plate	S42799-001	2
75-4	Adjusting plate	S42800-001	2
75-5	Work clamp, SE - OP	S42802-001	2
75-6	Screw, pan SM 3.57 - 40×5	062670-512	4

For gauge parts

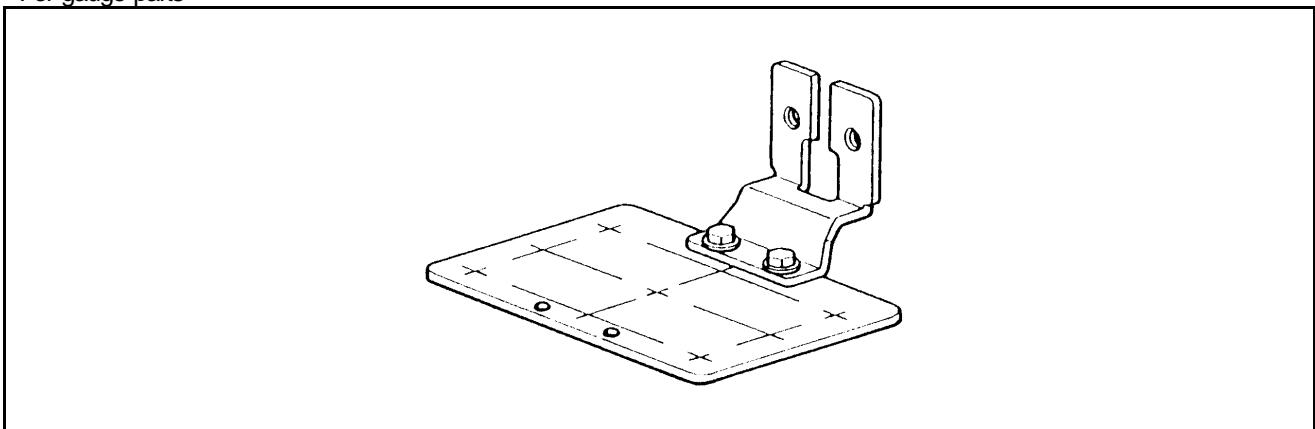

Part name	Part code	Q'ty
H-position standard plate assy	S42888-001	1

Feeder mechanism (Option parts)

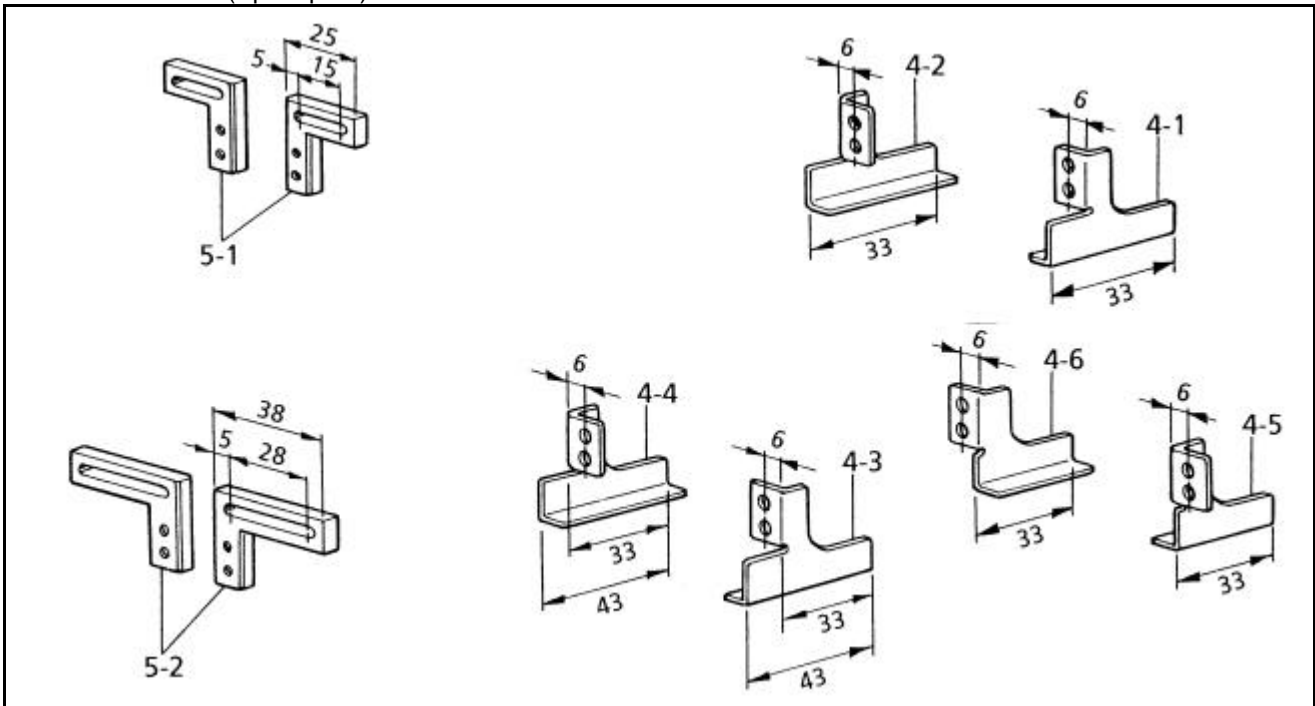

Ref. No.	Part name	Part code	Q'ty
4-1*	Folding plate, SR	S31295-000	1
4-2*	Folding plate, SL	S31296-000	1
4-3	Folding plate, LR	S31298-000	1
4-4	Folding plate, LL	S31297-000	1
4-5	Folding plate, SSR	S31299-000	1
4-6	Folding plate, SSL	S31300-000	1
5-1*	Folding plate set bracket, M	S31493-001	2
5-2	Folding plate set bracket, L	S31494-001	2

The * symbol is for standard part for BAS-315E.

Feeder mechanism (Option parts)

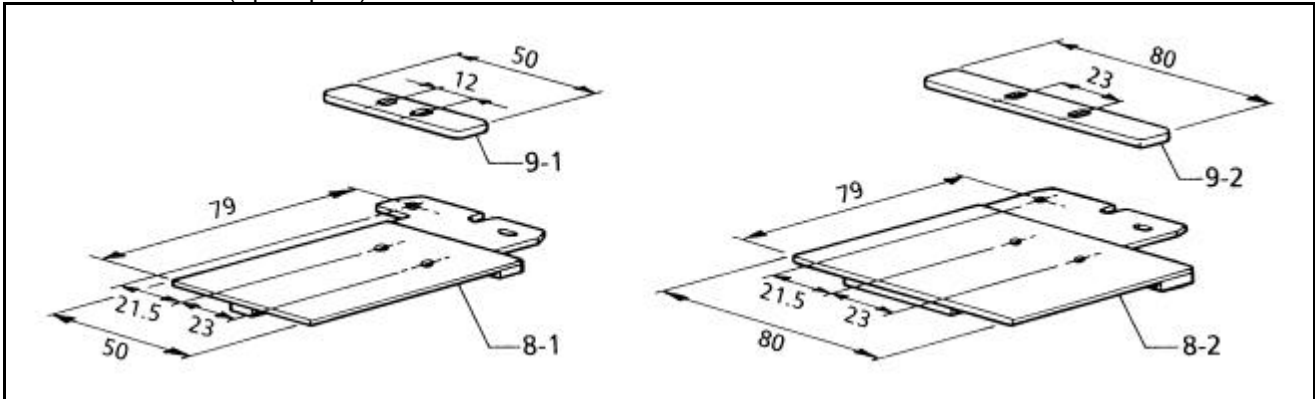

Ref. No.	Part name	Part code	Q'ty
8-1	Guide plate blank, S	S31290-000	1
9-1	Feed guide blank, S	S31292-000	1
8-2	Guide plate blank, L	S31291-000	1
9-2	Feed guide blank, L	S31293-000	1

Feeder mechanism

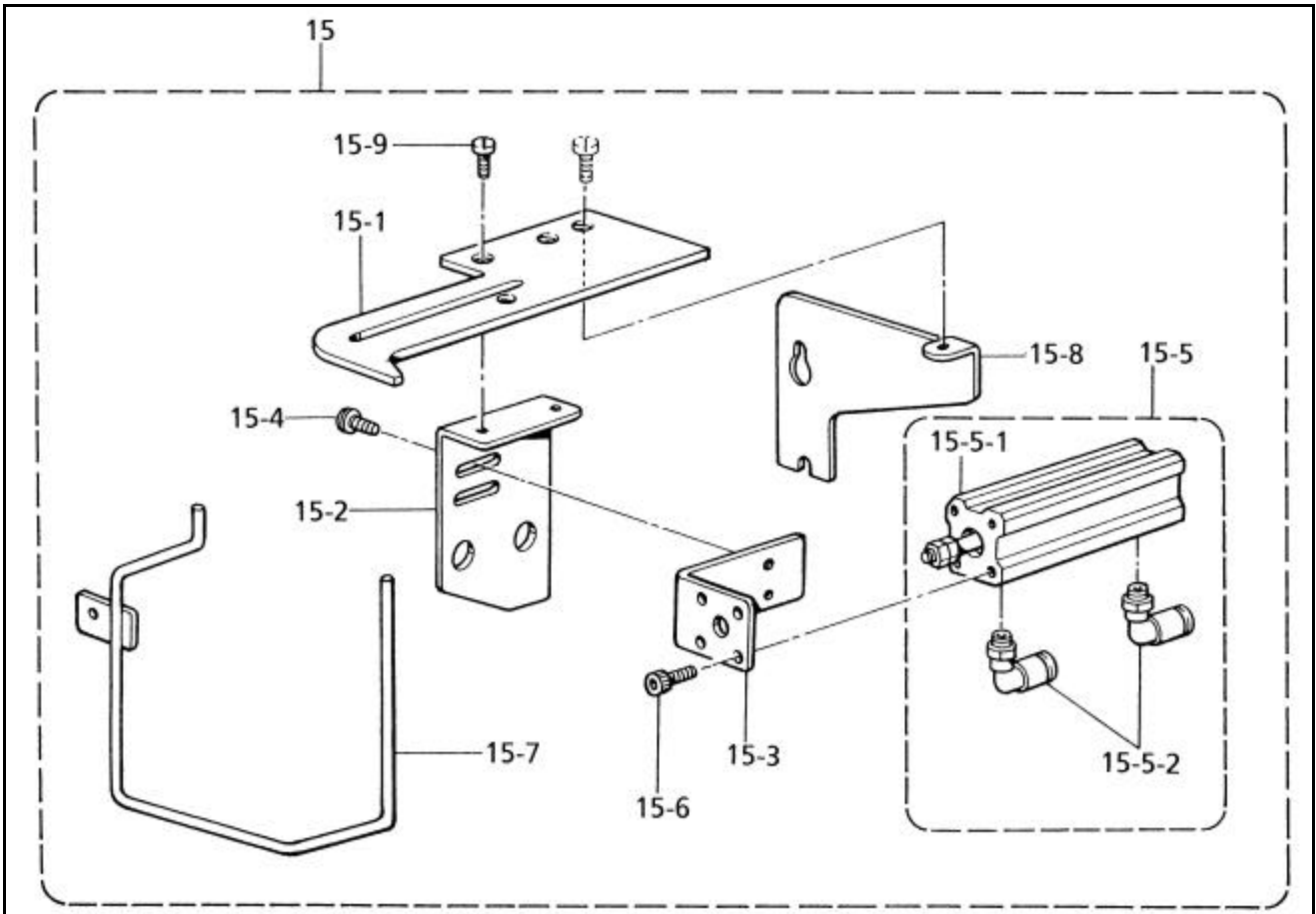

Ref. No.	Part name	Part code	Q'ty
15	Ejector assy	S30910-001	1
15-1	Support plate, IJ	S30911-001	1
15-2	Support plate guide, IJ	S30912-001	1
15-3	Cylinder fixed plate	S30913-001	1
15-4	Screw, button head M5×8	S18291-001	2
15-5	Cylinder assy, 12×50	S30914-000	1
15-5-1	Cylinder, 12×50	S30915-000	1
15-5-2	Elbow union, 4M5	S11426-000	2
15-6	Bolt, socket M4×8	018400-836	4
15-7	Cloth feed	S30916-001	1
15-8	Support L, auxiliary plate	S45260-001	1
15-9	Screw, SM4.37	106629-002	1

Feeder mechanism

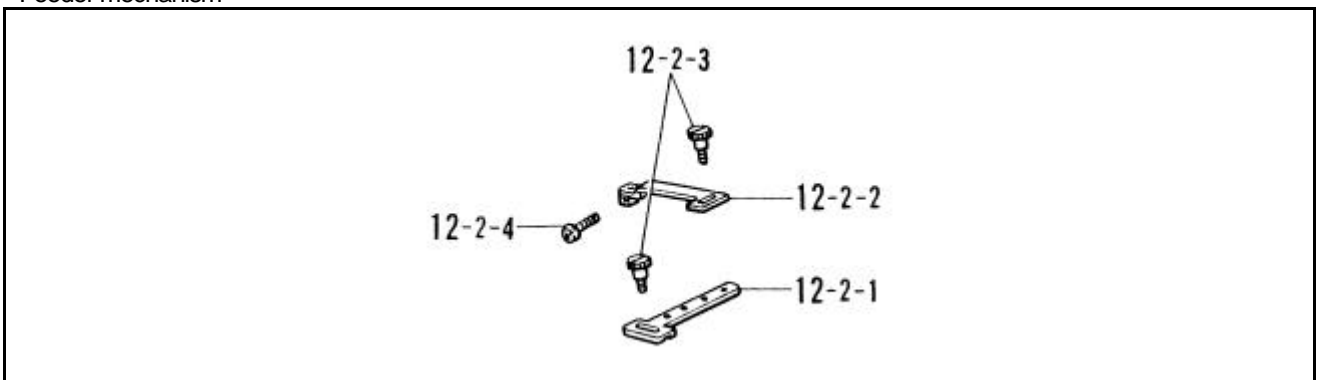

Ref. No.	Part name	Part code	Q'ty
12-2	Sensor set, F	S30847-001	1
12-2-1	Sensor holder plate, A	S31524-001	1
12-2-2	Sensor holder plate, B	S31525-101	1
12-2-3	Knob screw, M3.5	S30811-001	2
12-2-4	Screw, pan M3×6	062300-606	1

Auxiliary device (Option parts)

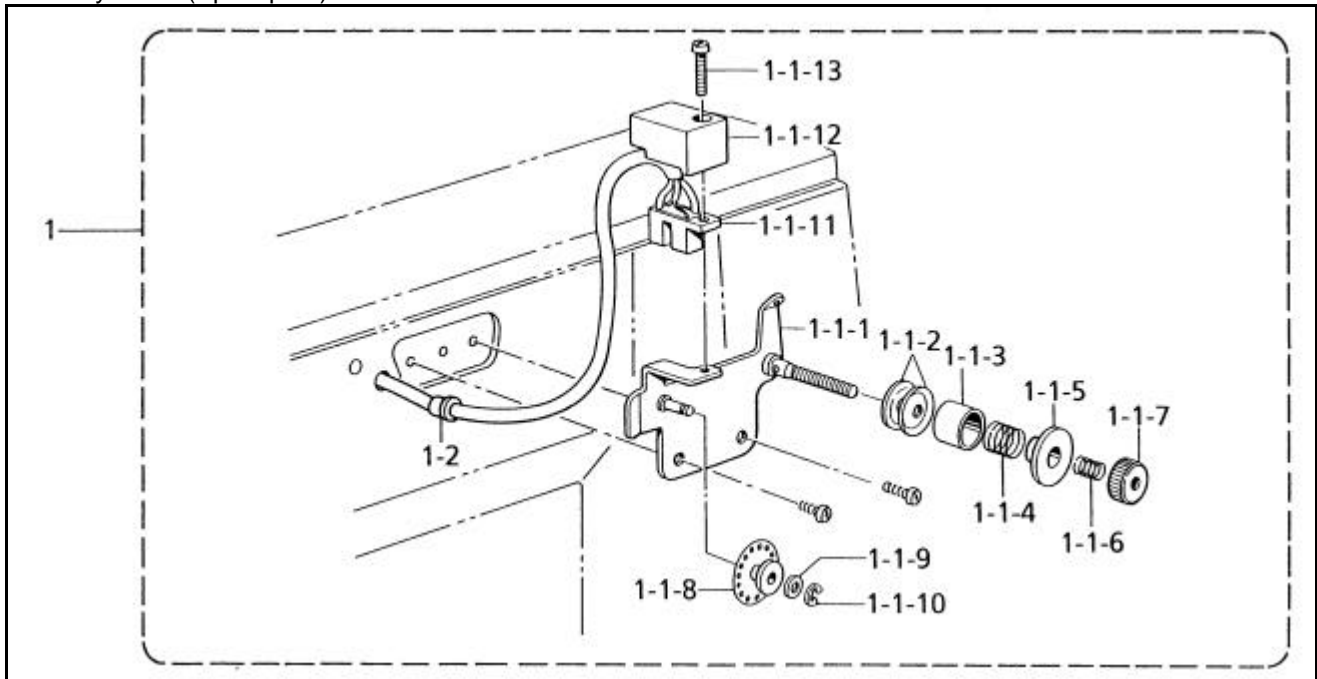

Ref. No.	Part name	Part code	Qty
"Thread breakage detector"			
< Rotary-type >			
1	TR breakage detector set, R	S43833-109	1
1-1	TR breakage detector assy, R	S43834-109	1
1-1-1	Detector bracket assy	S18032-001	1
1-1-2	Thread guide disc	144504-001	2
1-1-3	Thread guide disc presser	146206-009	1
1-1-4	Pre-tension spring	146058-001	1
1-1-5	Pre-tension nut	146059-001	1
1-1-6	Spring	146060-000	1
1-1-7	Tension nut	155510-001	1
1-1-8	Pulley, A	157255-100	1
1-1-9	Washer, plain S3	025030-135	1
1-1-10	Retaining ring, E2	048020-342	1
1-1-11	Sensor assy	S43835-000	1
1-1-12	Sensor cover	S18037-009	1
1-1-13	Screw, pan M3×16	062301-616	1
1-2	Cord bush	146080-000	1